

Broadband for All

The widespread use of broadband internet has become a prime condition to achieve productivity gains in the European economy as a whole and to capitalize in particular on the benefits for the society from eServices like eCare, eHealth, eGovernment or eSecurity. In the past years, several actions have been launched towards an EC initiative but, although significant growth has been observed in some member states, the mobile broadband has still to reach some of the EU's less-developed areas. Critical targets for global connectivity in 2015 include connecting all villages, educational institutions, government departments, health care centres and hospitals and ensuring that everyone has access to television and radio. Broadband coverage rates in rural areas are still low, due to the extremely high costs for fixed network operators to expand their infrastructures to these areas and the low performance available wireless solutions offer. There is no doubt that MIMAX can contribute to offering a

wireless network solution at lower cost and power consumption, and larger coverage range and reliability. This will result in improved user-acceptance and enforced competitive market positioning.



MIMAX: Advanced MIMO Systems for MAXimum Reliability and Performance

MIMAX Consortium



**MIMAX COORDINATOR:
DR.-ING. RALF EICKHOFF**

Helmholtzstrasse 18,
01069 Dresden
Tel: +49 (0)351 463-33084
Fax: +49 (0)351 463-38736
ralf.eickhoff@tu-dresden.de
<http://ccn.et.tu-dresden.de>

EU Project MIMAX

MIMAX: Advanced MIMO Systems for MAXimum Reliability and Performance

ICT 213952



www.ict-mimax.eu

... After 2 years

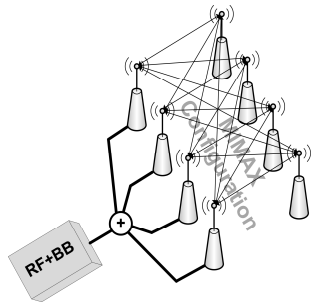

MIMAX MIMO infrastructure

MIMAX has assembled its first system prototype based on innovative hardware components, subsystems and algorithms. According to the specifications, the successful new components, subsystems and algorithms consist of:

- A four element antenna array using multi-band, microstrip-fed planar, F-shaped monopoles



- Multiple-Input/Multiple-Output (MIMO) algorithms for beamformer selection and channel estimation to support the new analogue front-end

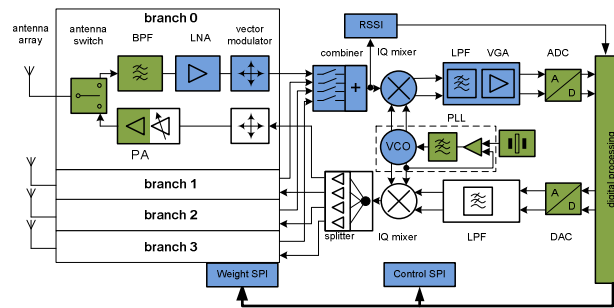

- An enhanced medium-access-control (MAC) processor for MIMAX specific tasks and compatibility to 802.11a

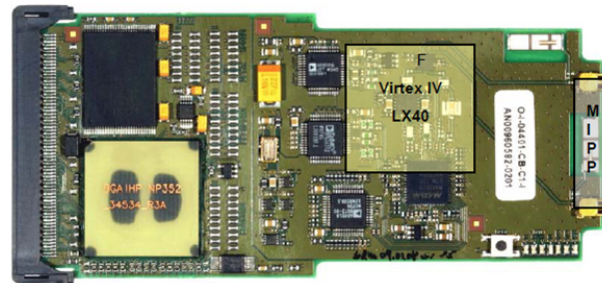

The first system prototype of MIMAX was verified, tested and evaluated with respect to the achievable performance in an indoor office/lab environment. Static and low mobility test cases successfully demonstrated the functionality of the newly developed system.

MIMAX DEMONSTRATOR

A Matlab GUI was developed by UC to easily handle the available hardware and monitor the radio channel.

This tool was employed for demos during exploitation events. The aim of the test bed is to prove performance enhancement of MIMAX over SISO (802.11a).

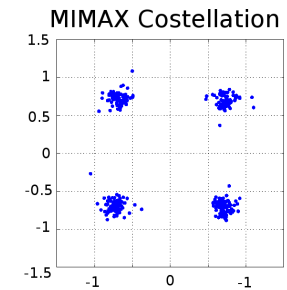

In Blue, the received constellation diagram is shown for MIMAX. It results in clearly less errors compared to a SISO 802.11a communication over the same channel (In Red).

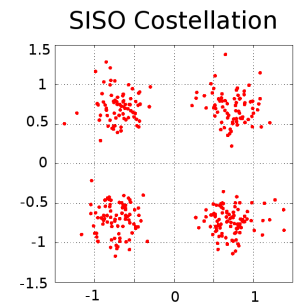

MIMAX COORDINATOR: DR.-ING. RALF EICKHOFF

MIMAX links:
ralf.eickhoff@tu-dresden.de
 Website: www.ict-mimax.eu